

# 1.View and size(视图及尺寸)

| Main technical indicators(主要技术指标) |  |
|-----------------------------------|--|
| 1.Mating (插拔次数)                   | 5000   |
| 2.Working Temperature (温度)        | -55~+150 °C  |
| 3.IP Rating (防护级别)                | IP 50  |
| 4.Diameter of socket end(插合端直径)   | ∅3.0   |
| 5.Testing Voltage (测试电压)          | 2100V  |
| 6.Working Voltage (工作电压)          | 1550V  |
| 7.Rated Current (额定电流)            | 35A  |
| 8.Shell material(壳体材质)            | Brass (chromium-plated) shell and nut/(nickel-plated) lock sleeve and middleware/黄铜(镀铬)外壳和螺母/(镀镍)锁套筒和中间件 |
| 9.Pin Material(插针材料)              | Copper alloy gold plating(铜合金镀金)   |
| 10.Insulator material(绝缘体材质)      | PPS  |

| Sum up(总结)                  |   |
|-----------------------------|---|
| Series(系列)                  | B   |
| Shell style/model (外壳样式/型号) | MKG: Fixed receptacle, nut fixing, cable collet(固定插座, 螺母固定, 电缆夹头) |
| Button (按键)                 | A button(一个按键)  |
| Termination type (终止类型)     | Mother solder tin(母焊锡)  |
| Line diameter awg(线材直径)     | 18-10AWG  |
| Cable diameter∅ (电缆直径)      | ∅6.3-7.2MM  |
| Match plug(匹配插头)            | TGG.3B.P02.CLAD72   |

| Location pin combination(定位销组合) |                                   |           |                         |
|---------------------------------|-----------------------------------|-----------|-------------------------|
| (编号) Number                     | Number of positioning pins(定位销数量) | Angle(角度) | Series(系列)--3B          |
| G                               | One(1)                            |           | (Zero degrees)0°        |
| A                               | Two(2)                            | A         | Thirty degrees(30°)     |
| B                               | Two(2)                            |           | Forty-five degrees(45°) |
| C                               | Two(2)                            |           | Sixty degrees(60°)      |
| D                               | Two(2)                            | γ         | 95 degrees (95°)        |
| E                               | Two(2)                            | β         | 120 degrees(120°)       |
| F                               | Two(2)                            |           | 145 degrees(145°)       |
| J                               | Two(2)                            | A         | 37.5degrees(37.5°)      |
| K                               | Two(2)                            |           | 52.5degrees(52.5°)      |
| L                               | Two(2)                            | γ         | Seventy degrees(70°)    |

|        | A      | B      | C√     | ANGLE   |       |
|--------|--------|--------|--------|---------|-------|
| 5-10   | ±0.02  | ±0.05  | ±0.1   | 0°-30°  | ±0.1° |
| 50-100 | ±0.1   | ±0.15  | ±0.2   | 61°-90° | ±0.5° |
| 50-100 | ±0.15  | ±0.2   | ±0.25  |         |       |
| 100-   | ±0.15% | ±0.20% | ±0.25% |         |       |

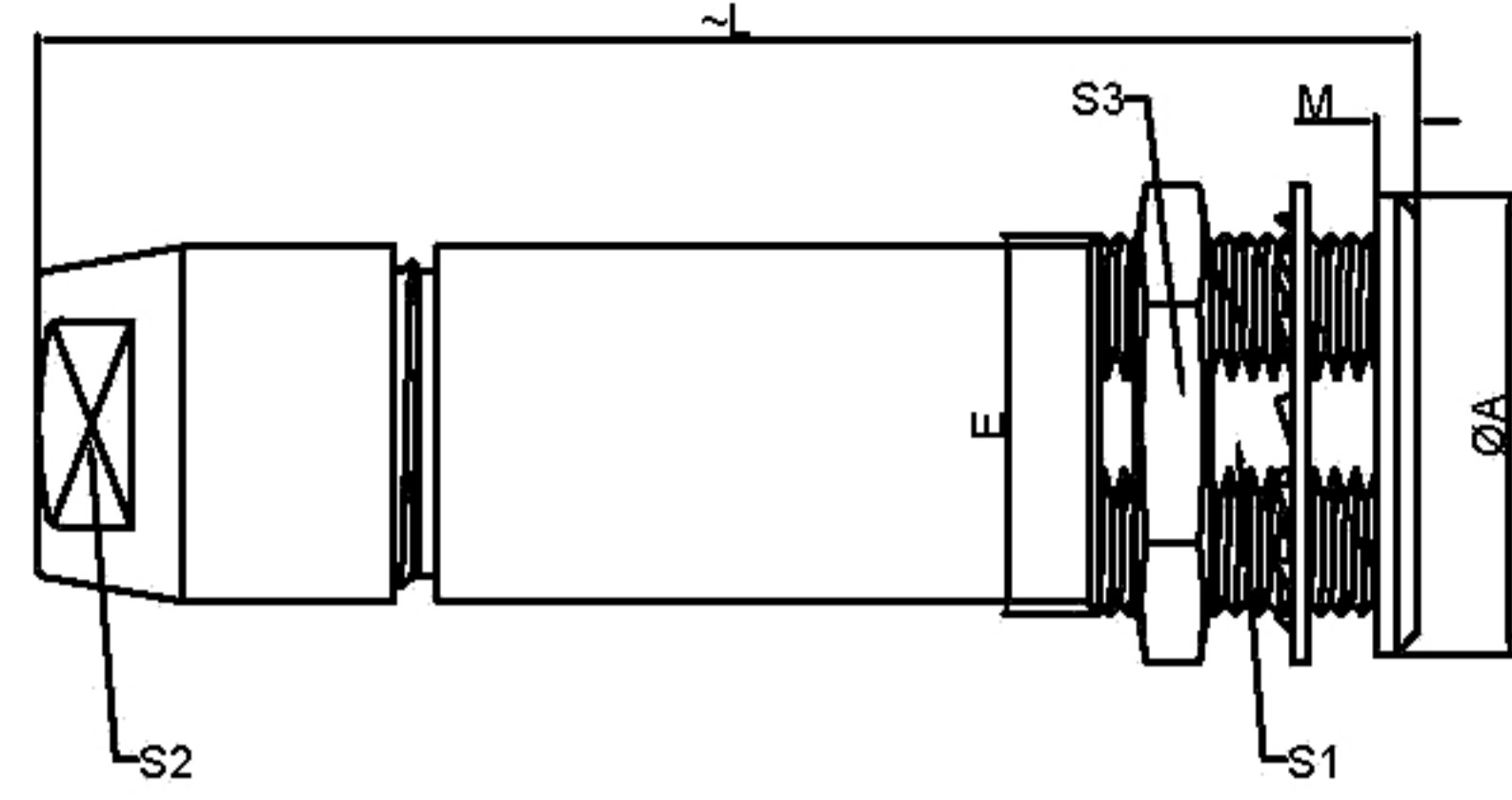

|    | ∅A     | e      | L      | M      | S1     | S2     | S3     |
|----|--------|--------|--------|--------|--------|--------|--------|
| MM | ∅22    | M18*1  | 56.0   | 2.0    | 16.5   | 14.0   | 22.0   |
| in | 0.8661 | 0.0000 | 2.2047 | 0.0787 | 0.6496 | 0.5512 | 0.8661 |

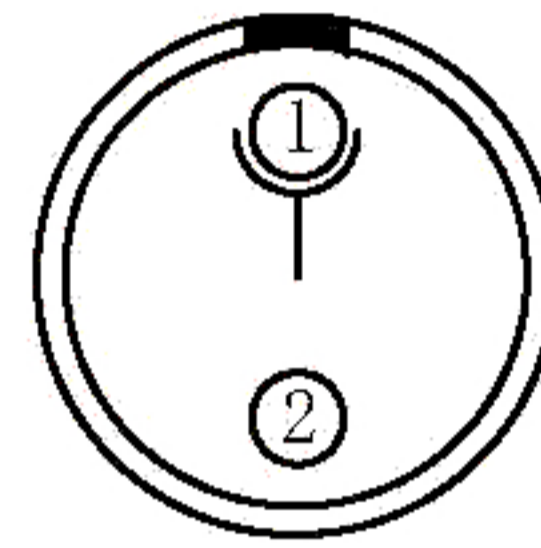

Welded surface (焊接面)

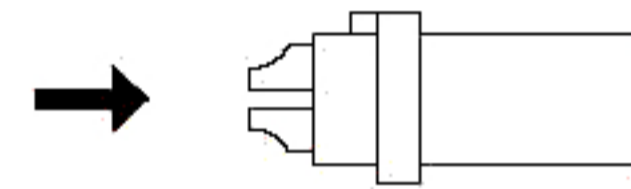

(Welded mother adhesive core) 焊接型母胶芯

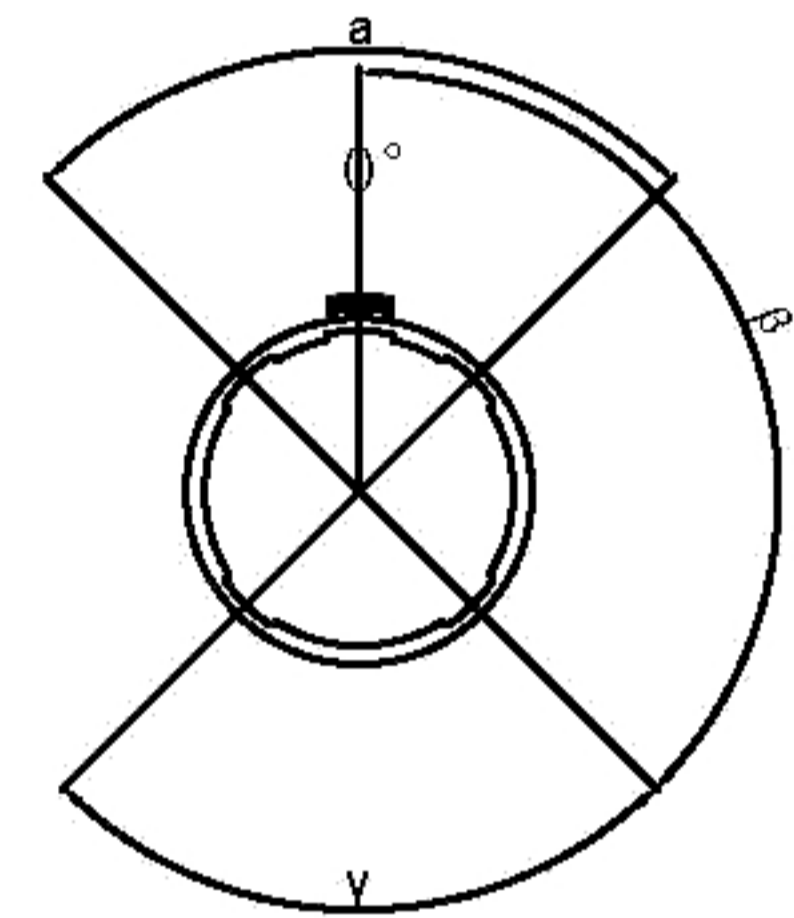

Positive view of the socket (插座正视图)

**MK G. 3B. P02.C L L D 72**

- Model(型号) \_\_\_\_\_
- Positioning pin(定位销) \_\_\_\_\_
- Series(系列) \_\_\_\_\_
- Needle core configuration(针芯配置) \_\_\_\_\_
- Outer casing(外壳) \_\_\_\_\_
- Insulator(绝缘体) \_\_\_\_\_
- Needle core(针芯) \_\_\_\_\_
- Type of clamp(线夹类型) \_\_\_\_\_
- Cable diameter(电缆直径) \_\_\_\_\_

|                                  |  |          |                                      |               |          |  |
|----------------------------------|--|----------|--------------------------------------|---------------|----------|--|
| DESIGNED(设计)                     |  | DATE(日期) |                                      | SCALE(比例)     | N/A(不适用) | MODEL TYPE                             |
| CHECKED(校对)                      |  | DATE(日期) |                                      | VIEW(视图)      |          | 型号类型: MKG.3B.P02.CLLD72                |
| APPROVED(审核)                     |  | DATE(日期) |                                      | UNIT(单位)      | MM       | PART NO. 3B2 core socket<br>名称: 3B2芯插座 |
| <b>REVISIONS</b>                 |  |          |                                      | MATERIAL (材料) |          | DWG NO.:                               |
| www.helloxkb.com www.helloxkb.cn |  |          | XKB INDUSTRIAL PRECISION CO.,LIMITED |               |          | WEIGHT(重量) SHEET(表) REVISION(修订)       |
|                                  |  |          |                                      |               |          | 1/1 A0                                 |