

1.View and size(视图及尺寸)

Main technical indicators(主要技术指标)	
1.Mating (插拔次数)	5000
2.Working Temperature (温度)	-55~+150 °C
3.IP Rating (防护级别)	IP 54
4.Diameter of socket end(插合端直径)	φ0.7
5.Testing Voltage (测试电压)	850V
6.Working Voltage (工作电压)	1200V
7.Rated Current (额定电流)	5A
8.Shell material(壳体材质)	Brass (chromium plating)/(nickel plating) fixation ring/ 黄铜 (镀铬) / (镀镍) 固定圈
9.Pin Material(插针材料)	Copper alloy gold plating(铜合金镀金)
10.Insulator material(绝缘体材质)	PPS

Sum up(总结)	
Series(系列)	B
Shell style/model (外壳样式/型号)	HGG:Fixed receptacle, nut fixing, watertight or vacuum-tight/固定插座, 螺母固定, 水密或真空密
Button (按键)	A button(一个按键)
Termination type (终止类型)	Mother solder tin(母焊锡)
Line diameter awg(线材直径)	30-22AWG
Cable diameterφ (电缆直径)	φ1.4-9.9MM
Match plug(匹配插头)	TGG.2B.P19.CLAD52H

Location pin combination(定位销组合)			
(编号) Number	Number of positioning pins(定位销数量)	Angle(角度)	Series(系列)--2B
G	One(1)		(Zero degrees)0°
A	Two(2)	A	Thirty degrees(30°)
B	Two(2)		Forty-five degrees(45°)
C	Two(2)		Sixty degrees(60°)
D	Two(2)	γ	95 degrees (95°)
E	Two(2)	β	120 degrees(120°)
F	Two(2)		145 degrees(145°)
J	Two(2)	A	37.5degrees(37.5°)
K	Two(2)		52.5degrees(52.5°)
L	Two(2)		γ

	A	B	C√	ANGLE	
5-10	±0.02	±0.05	±0.1	0°-30°	±0.1°
50-100	±0.1	±0.15	±0.2	61°-90°	±0.5°
50-100	±0.15	±0.2	±0.25		
100-	±0.15%	±0.20%	±0.25%		

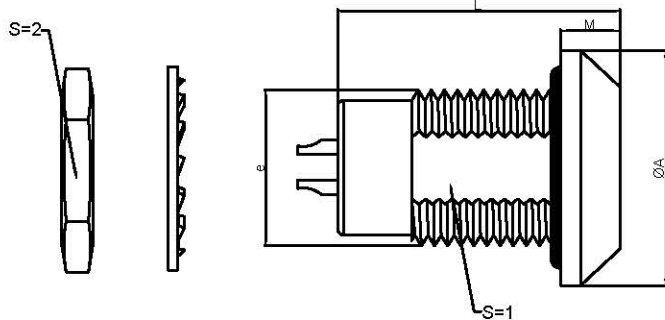

	A	L	E	M	S1	S2
MM	20	28.0	M15*1	4	13.5	17
in	0.7874	1.1024		0.1575	0.5315	0.6693



Welded surface (焊接面)

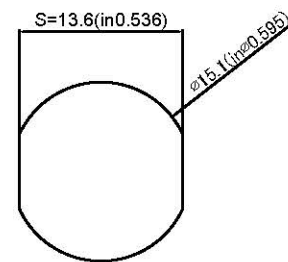

Panel hole size (面板开孔尺寸)

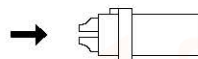

(Welded mother adhesive core) 焊接型母胶芯

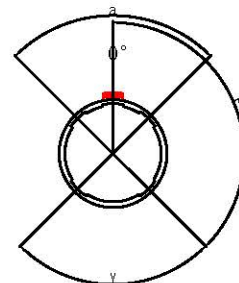

Positive view of the socket (插座正视图)

HGG.2B.P19.C L L

- Model(型号)
- Positioning pin(定位销)
- Series(系列)
- Needle core configuration(针芯配置)
- Outer casing(外壳)
- Insulator(绝缘体)
- Needle core(针芯)

DESIGNED(设计)		DATE(日期)		SCALE(比例)	N/A(不适用)	MODEL TYPE
CHECKED(校对)		DATE(日期)		VIEW(视图)		型号类型: HGG.2B.P19.CLL
APPROVED(审核)		DATE(日期)		UNIT(单位)	MM	PART NO. 2B19 core socket 名称: 2B19芯插座
REVISIONS				MATERIAL (材料)		DWG NO.:
www.helloxkb.com www.helloxkb.cn				XKB INDUSTRIAL PRECISION CO.,LIMITED		WEIGHT(重量) SHEET(表) REVISION(修订)
						1/1 A0